

Sensor – Throttle Position – Remove and Install (23 325 0)

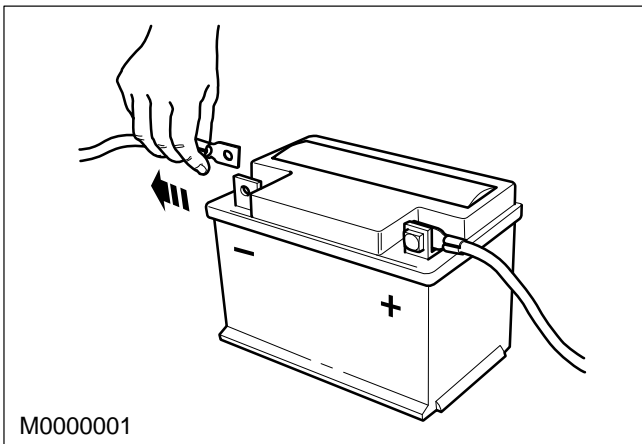

Remove

1. Disconnect the battery earth lead.
2. Remove the VIS actuator (refer to Operation Number 23 400 0).

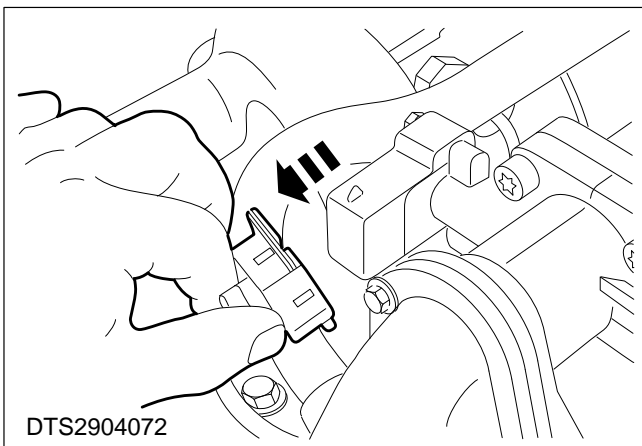

3. Disconnect the TP sensor multiplug.

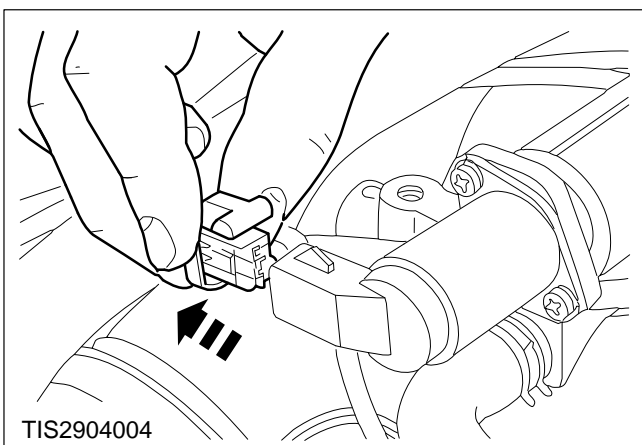

4. Disconnect the IAC valve multiplug.

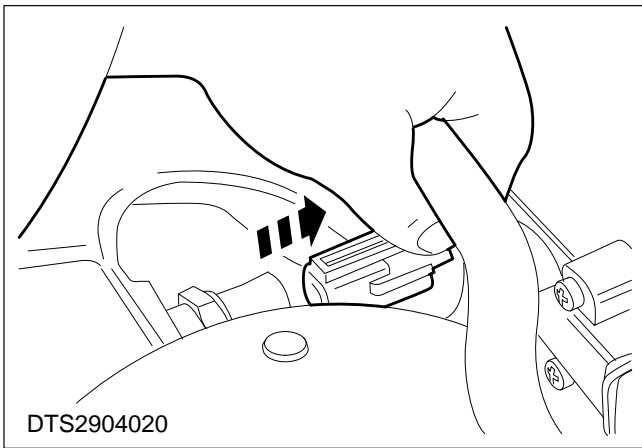

5. Disconnect the IAT sensor multiplug.

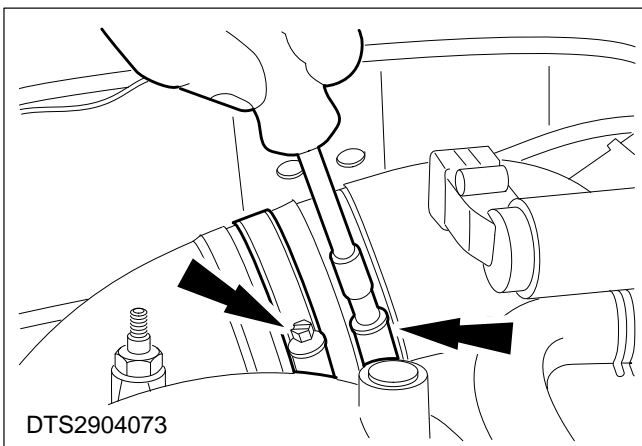

6. Slacken the connecting sleeve clips.

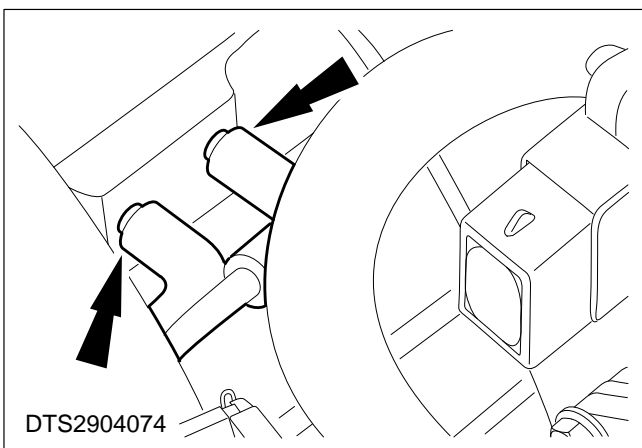

7. Disconnect the vacuum pipes.

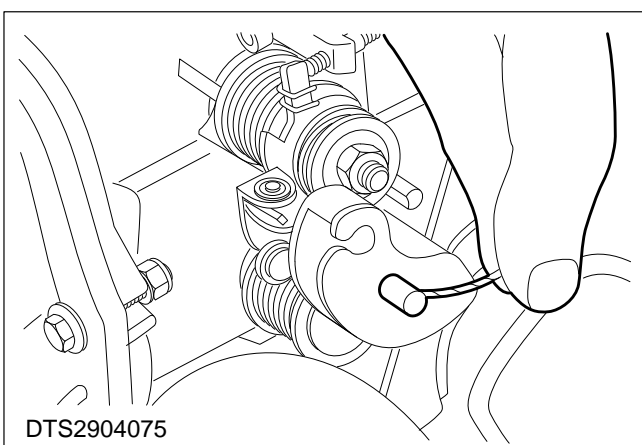

8. Disconnect the accelerator cable (and speed control system cable if fitted) from the quadrant.

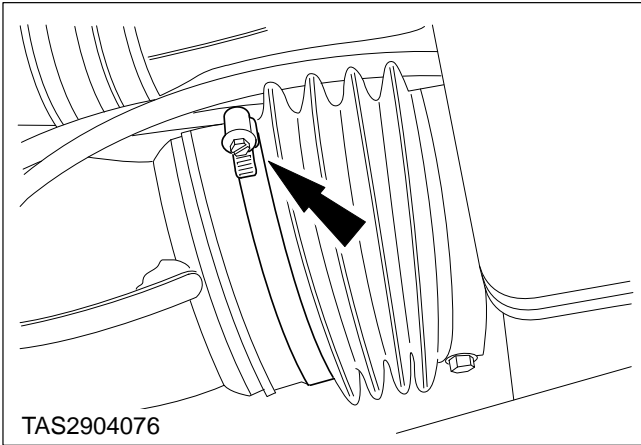

9. Slacken the hose clip on the inlet ducting.

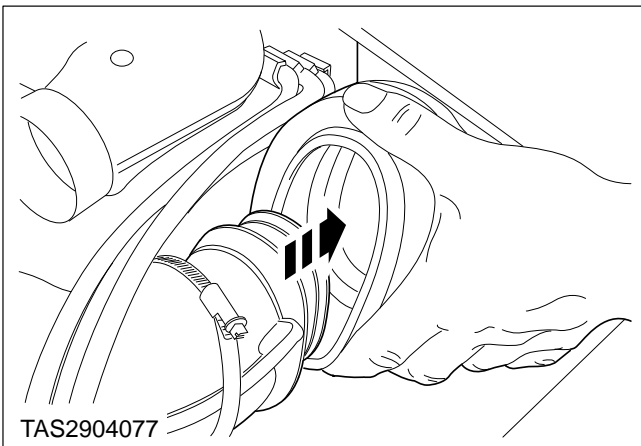

10. Disconnect the resonator from the inlet ducting.

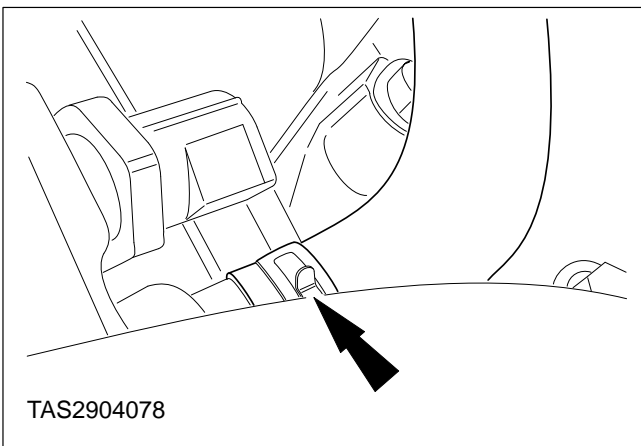

11. Disconnect the breather pipe.

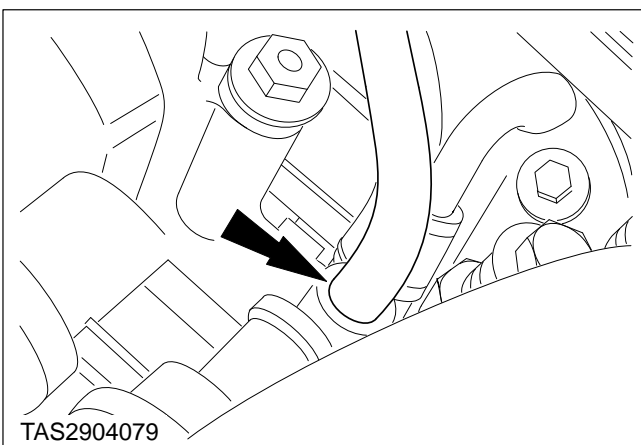

12. Disconnect the vacuum pipe.

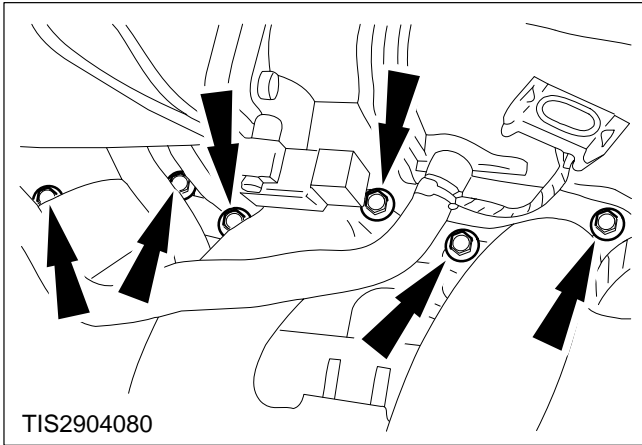

13. Remove the plenum bolts.

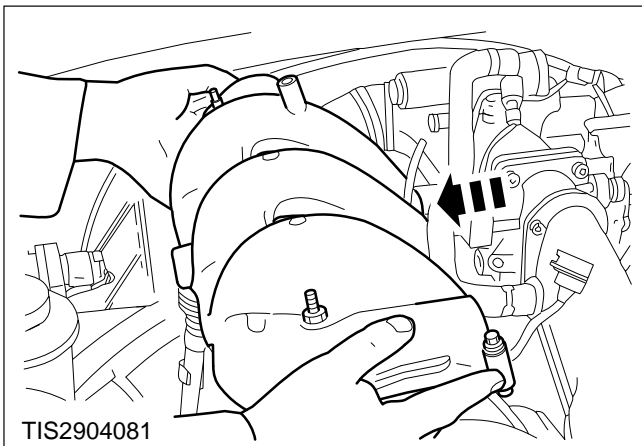

14. Lift the plenum section off the engine.

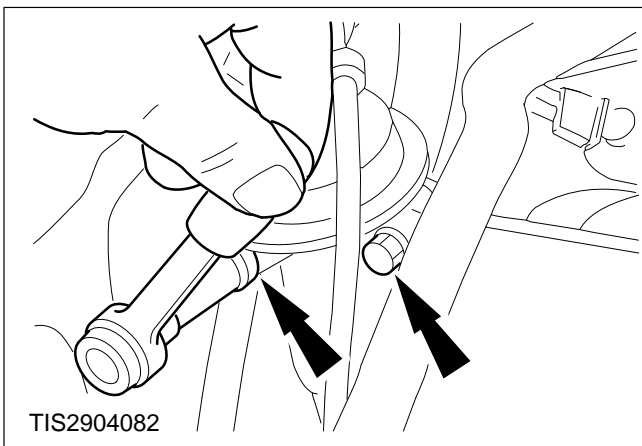

15. Remove the EGR valve bolts.

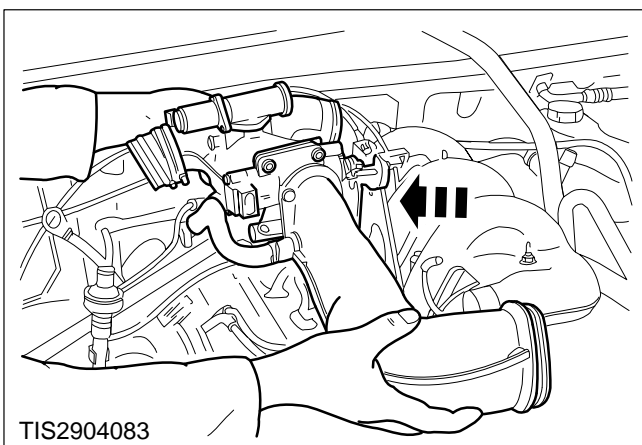

16. Lift the plenum centre section, complete with throttle body housing, off the engine.

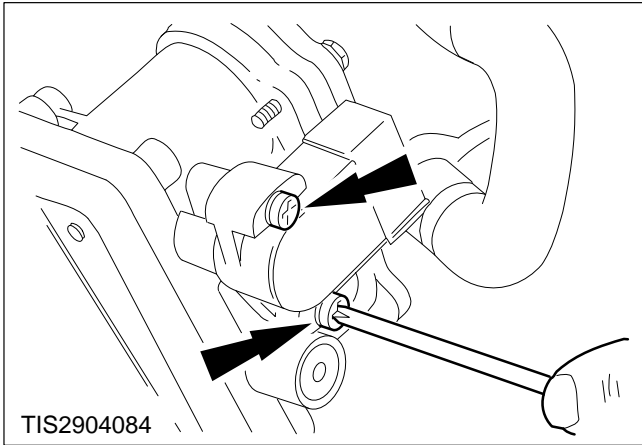

17. Remove the TP sensor retaining screws.

Install

18. Refit the components in reverse order.